

# Bilge Level Switch

## UNS-VA/SB1-VA52

### Level switch without test function

#### Features

- Particularly rugged and sturdy design for bilge monitoring

#### Applications

- Shipbuilding
- Sewage works

#### Technical Data

Stem, housing and screw coupling	Stainless steel 1.4571
Ball float	VA52, Ø = 52 mm
Operating pressure	max. 10 bar
Temperature range	max. -20 °C ... +80 °C
Fluid specific gravity	min. 0.70 g/cm <sup>3</sup>
Attachment	Holding bracket
Protection class	IP67
Electrical connection	Shipbuilding or marine cable
Cable length	2 m (Standard), 5 m, 10 m
Contact	1 - normally open contact (NO) 2 - normally closed contact (NC) 3 - change-over contact (WE)
Contact rating	1 - 250 V AC/DC / 3.0 A / 100 W / VA 2 - 250 V AC/DC / 3.0 A / 100 W / VA 3 - 140 V AC/DC / 1.0 A / 60 W / VA
Weight	ca. 735 g
Approvals	DNV, BV, RINA
EX Approval	IECEX TUN 17.0039X TÜV 18 ATEX 214370 X II 1 G Ex ia IIC T6 Ga or II 1/2 G Ex ia IIC T6 Ga/Gb or II 2 G Ex ia IIC T6 Gb or II 1 D Ex ia IIIC T100°C Da



#### Dimensions (mm / inch)

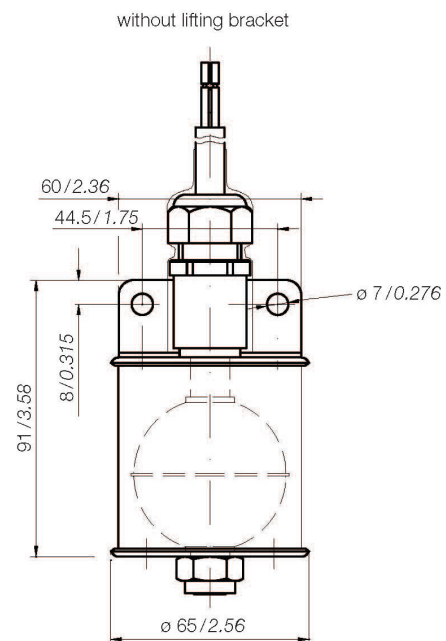

#### Order Code

Type	Contact type	Cabel length	Order No.
UNS-VA/SB1-VA52	NO (NC) SPST	2 m	0111-623
		5 m	0111-624
		10 m	0111-625
	WE SPDT	2 m	0111-629
		5 m	0111-630
		10 m	0111-631

#### Color code NO (NC)

