

7 Technical Data

7.1 Dimensions

BFS-10-N / N-Air

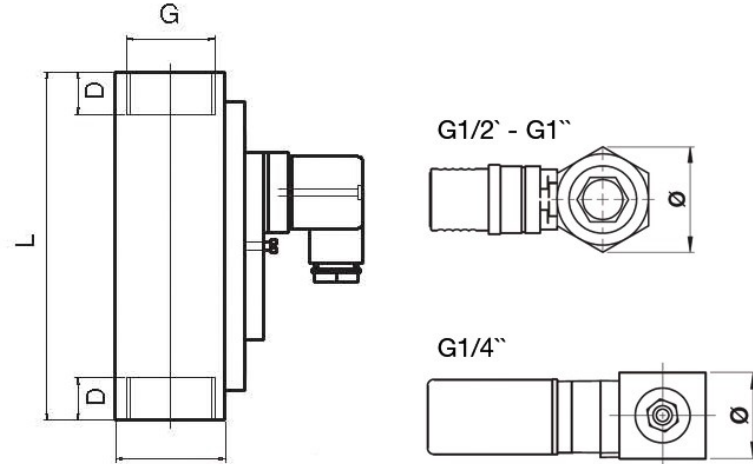

(G)	G 1/4	G1/2	G 1
(Ø)	17	31	50
(W)	47	52	72
(D)	10	14	17
(L)	65	90	158
Weight (g)	140	350	1050

Operating Instructions
Flow monitor type BFS-10-N / N-Air



1	Intended Applications	2
2	Safety Instructions	2
3	Standards.....	3
4	Warranty/Guaranty	3
5	Installation	4
6	Maintenance/Cleaning.....	6
7	Technical Data	8

Barksdale GmbH

Dorn-Assenheimer Straße 27
D-61203 Reichelsheim

Phone: +49 (6035) 949-0
Fax: +49 (6035) 949-111 and 949-113
eMail: info@barksdale.de
Internet: www.barksdale.de

<p>Art. no. 923-2805 Index: A, 16.02.2024 Specifications are subject to changes without notice! Refer to data sheet for further technical data.</p>	
---	--

1 Intended Applications

The flow monitor is designed exclusively for measuring and monitoring fluid media, e.g. in cooling systems, measuring and test equipment and pumps. All non-standard applications should be discussed with our engineers.

Read the operating instructions and the safety instructions carefully before using the flow monitor. Nonobservance may cause injuries to health or material damage.

Barksdale GmbH cannot be held liable for any damage resulting from incorrect use.

CAUTION

 When used in zone 0, the atmospheric pressure must be between EN IEC 60079-0:2018, IEC 60079-0:2017 must be between 0.8 and 1.1 bar absolute. If the flow monitor (BFS-10-N) is used in a potentially explosive atmosphere outside the permissible pressure range, the type examination certificate serves only as a guideline

DANGER

Danger due to electrostatic discharge - Metallic process connection parts must be included in the local equipotential bonding (TÜV 20 ATEX 248479 X)

DANGER

The flow monitor may only be used in the specified fields of application (see nameplate).
The temperatures must be within the specified ranges, the pressure values and the electrical rating must not exceed the values specified.
Inside the device no explosive mixture (gas/air, dust/air or hybrids) may occur at any time. This is to be guaranteed by the operator.

Observe also the applicable national safety instructions for assembly, commissioning and operation of the flow monitor.

2 Safety Instructions

The safety instructions are intended to protect the user from dangerous situations and/or material damage. In the operating instructions the seriousness of the potential risk is designated by the following signal words:

DANGER

Refers to imminent danger to men.
Nonobservance may result in fatal injuries.

WARNING

Refers to a recognizable danger.
Nonobservance may result in fatal injuries, and destroy the equipment or plant parts.

CAUTION

Refers to a danger.
Nonobservance may result in light injuries and material damage to the switch and/or to the plant.

IMPORTANT

Refers to important information essential to the user.

Disposal

The flow monitor must be disposed of correctly in accordance with the local regulations for electric/electronic equipment.
The flow monitor must not be disposed of with the household garbage!

3 Standards

The standards applied during development, manufacture and configuration are listed in the CE conformity and manufacturer's declaration.

4 Warranty/Guaranty

Warranty

Our scope of delivery and services is governed by the legal warranties and warranty periods.

Terms of guaranty

We guaranty for function and material of the flow monitor under normal operating and maintenance conditions in accordance with the statutory provisions.

Loss of guaranty

The agreed guaranty period will expire in case of:

- incorrect use
- incorrect installation
- incorrect handling or operation contrary to the provisions of these operating instructions

No liability is assumed for any damage resulting therefrom, or any consequential damage.

5 Installation

	IMPORTANT
The flow monitor may only be installed and commissioned by trained staff.	

The instrument can be installed in any position in a system due to the use of a spring resetting the float to its initial position. Flow direction is from the lowest to the highest value indicated on the scale.

	IMPORTANT
The medium must be free of solid contamination and magnetic particles.	
We recommend the use of dirt filters.	

	IMPORTANT
The flow monitors must not be positioned in inductive or strong magnetic fields. The screw connection should be non-magnetic.	

All standard connections comply with DIN ISO 228-1. Ensure that only suitable threads and sealing materials are used for installation, otherwise correct functioning and tightness of the equipment may be impaired.

To avoid the risk of measuring faults the upstream line should be 10 x D and the downstream line 5 x D (D = nominal diameter of the tube).

The highest accuracy will be reached by installing the flow monitor vertically, with the flow direction from the bottom to the top. When the flow monitor is installed in any other position, deviations may occur due to the weight of the float.

	CAUTION
BFS-10-N: Too long threads may impair the function of the flow monitor or cause damage to the flow monitor.	
Observe the maximum length when screwing in the fittings.	

5.1 Connecting the flow monitor

Flow monitor with contact (standard): the electrical connection values stated on the housing should never be exceeded (not even for short periods). The integrated reed contact is very sensitive to overload. The danger of overloads exist by means of:

- Inductive loads
- Capacitive loads
- Resistive loads

Inductive load

Inductive loads will be caused by contactors, relays / solenoid valves / electricmotors

	CAUTION
Voltage peaks during switch off (up to 10-times of the nominal voltage)	

Precautionary measure: (sample)

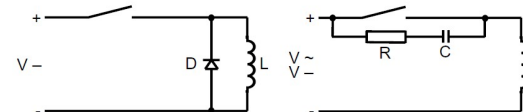

Capacitive load

This kind of load will be caused by extrem long leads / capacitive consumption

	CAUTION
High current peaks during switch on the switch contact (exceeding the nominal current)	

Precautionary measure: (sample)

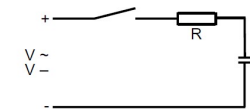

Limiting the current by means of a resistor

Resistive load

This kind of load will be caused by incandescent bulbs / Motor start up

	CAUTION
High current peaks during switch on of the switch contact, because the filament has low resistance at low temperatures.	

Precautionary measure: (sample)

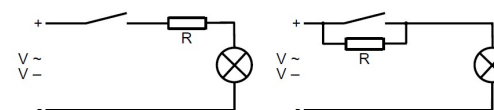

Limiting the current by means of a resistor of heating of the filament.

Connection to SPS

For the connection to high resistance devices (like SPS) a protection circuit is not necessary.

The reed contacts are tungsten, gold-rhodium-plated and are installed in an inert gas atmosphere. Hence direct connection to the inputs of a PLC system is possible.

Wiring diagram for switches provided with connector (standard)

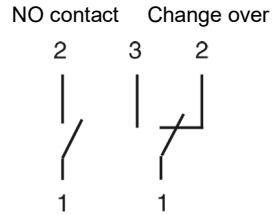

5.2 Adjusting the switching point

The switching point is adjusted via the scale on the flow monitor. Please take into account that the scale always indicates the shut-down point. That means:

- when the flow rate is decreasing the NO (Normaly Open) contact will open when the set volume is reached
- when the flow rate is sufficient, the NO (Normaly Open) contact is closed
- in case of an alarm (flow rate too low) the NO (Normaly Open) contact will open

6 Maintenance/Cleaning

	IMPORTANT
Maintenance of the flow monitor may only be carried out by trained staff.	

The flow monitor has only a few moving parts. Maintenance only involves cleaning these parts from time to time.

	IMPORTANT
Comply with the torque values provided in the pipeline construction.	
Tightening torques for cable glands (which are delivered):	
DIN plug (EN 175 301-803 A), cap nut	2,5 ... 3,75 Nm
DIN plug (EN 175 301-803 A), M3 screw	0,5 ... 0,6 Nm
S1 connector (EN 175 301-803 C)	0,2 Nm
M20 x 1,5 - 1/2"NPT reducer	30 Nm max.
G 1/4" hose connection gland	1,5 Nm

6

Approval data for BFS-10-...-EXI

Optionally there is an intrinsically safe approved version of the flow monitor for gas and dust environments according to ATEX/IECEX regulations.

These intrinsically safe switches marked with Ex ia label must be operated with a certified switch amplifier.

Approval:	II 1 G Ex ia IIB T6 Ga II 1 D Ex ia IIIC T100°C Da
Certificate no.:	TÜV 20 ATEX 248479 X, IECEx TUN 20.0003X
Permissible ambient temperature:	-40 °C ≤ T _a ≤ +75 °C
Electrical data for intrinsically safe application:	U _i = 28 V I _i = 110 mA P _i = 0.84 W
Effective internal capacitance:	C _i = capacitance of the permanently connected cable
Effective internal inductance:	L _i = inductance of the permanently connected cable
For the connected cable the following applies:	C _{c, Ader/Ader} + C _{c, Ader/Schirm} ≤ 200 pF/m L _c ≤ 1 µH/m
Standards applied:	EN IEC 60079-0:2018, IEC 60079-0:2017 EN 60079-11:2012, IEC 60079-11:2011

	CAUTION
Special conditions for use	
The flow switch must be installed and used in such a way that electrostatic charges are eliminated by operation, maintenance and cleaning.	
For the use in areas that require EPL Da the flow switch type BFS-10-N-a-b-c-d-e-f must be protected from strong charge generation mechanisms.	